

Name: _____

Standard NC.5.OA.2

Unit 1 Study Guide

Use the information to answer questions

1–3.

Karl, Liam, and Maggie each collect rocks. Karl has 144 rocks. Karl has twice as many rocks as Liam. Maggie has 3 times as many rocks as Liam.

- Which describes a process for determining how many rocks Maggie has?
 - Find the product of 144 and 2. Then multiply by 3.
 - Find the quotient of 144 and 2. Then multiply by 3.
 - Find the product of 144 and 3. Then divide by 2.
 - Find the quotient of 144 and 3. Then divide by 2.
- Which expression represents the number of rocks Maggie has?
 - $144 \div (2 \times 3)$
 - $(144 \times 2) \times 3$
 - $(144 \div 2) \times 3$
 - $(144 \div 3) \div 2$
- How many rocks does Maggie have?
 - 864
 - 216
 - 48
 - 24

Use the information to answer questions

4–6.

Marci cooks $\frac{7}{8}$ pound of chicken. She eats $\frac{2}{8}$ pound of chicken for lunch. She feeds some of the chicken to her dog. Marci has $\frac{4}{8}$ pound of chicken left.

- How could Marci determine how many pounds of chicken she feeds her dog?
 - Subtract $\frac{4}{8}$ from the sum of $\frac{7}{8}$ and $\frac{2}{8}$.
 - Add $\frac{4}{8}$ to the difference of $\frac{7}{8}$ and $\frac{2}{8}$.
 - Subtract $\frac{4}{8}$ from the difference of $\frac{7}{8}$ and $\frac{2}{8}$.
 - Subtract the difference of $\frac{4}{8}$ and $\frac{2}{8}$ from $\frac{7}{8}$.
- Which expression represents the number of pounds of chicken Marci feeds her dog?
 - $(\frac{7}{8} - \frac{2}{8}) - \frac{4}{8}$
 - $(\frac{7}{8} - \frac{2}{8}) + \frac{4}{8}$
 - $\frac{7}{8} + (\frac{2}{8} + \frac{4}{8})$
 - $(\frac{7}{8} + \frac{2}{8}) - \frac{4}{8}$
- How many pounds of chicken does Marci feed her dog?
 - $\frac{5}{8}$ lb
 - $\frac{3}{8}$ lb
 - $\frac{2}{8}$ lb
 - $\frac{1}{8}$ lb

Name: _____

Standard NC.5.NBT.1

Unit 1 Study Guide

1. This table shows the high scores for the top five players on a video game.

Player	Score
Player 1	401,987
Player 2	359,847
Player 3	321,795
Player 4	297,634
Player 5	972,863

Which score contains a 9 with a value 10 times as much as the 9 in the score for player 2?

- A. 972,863
 - B. 401,987
 - C. 321,795
 - D. 297,634
2. Last summer, Jon earned \$916.55 mowing lawns. His brother earned \$91.65 completing chores at home. Compare the value of the 9 in each of the two numbers. How do the values compare?
- A. The value of the 9 in Jon's number is 100 times the value of the 9 in his brother's number.
 - B. The value of the 9 in Jon's number is 10 times the value of the 9 in his brother's number.
 - C. The value of the 9 in Jon's number is the same as the value of the 9 in his brother's number.
 - D. The value of the 9 in Jon's number is $\frac{1}{10}$ the value of the 9 in his brother's number.

3. The volume of a cylinder is 5.024 cubic inches. Which number contains a 4 with a value 10 times as much as the 4 in 5.024?

- A. 13.704
- B. 8.245
- C. 4.01
- D. 0.46

4. Jennifer and Julie sold cookies for their school. Jennifer's sales totaled \$475.00, while Julie's totaled \$47.50. Which statement is **not** correct?

- A. The 4 in Jennifer's sales has a value 10 times as much as the 4 in Julie's sales.
- B. The 7 in Julie's sales has a value $\frac{1}{10}$ as much as the 7 in Jennifer's sales.
- C. The 4 in Jennifer's sales has a value 100 times as much as the 4 in Julie's sales.
- D. The 5 in Jennifer's sales has a value 10 times as much as the 5 in Julie's sales.

5. How does the value of 6 one-dollar bills compare to the value of 6 dimes?

- A. It is 10 times as much as 6 dimes.
- B. It is $\frac{1}{10}$ the value of 6 dimes.
- C. It is 6 times as much as 6 dimes.
- D. It is 60 times as much as 6 dimes.

Name: _____

Standard NC.5.OA.2

Unit 1 - Study Guide

1. Arlo writes these equations.

$$12 + 4 = 4 + 12 \qquad 12 - 4 = 4 - 12$$

$$12 \times 4 = 4 \times 12 \qquad 12 \div 4 = 4 \div 12$$

How many of Arlo's equations are correct?

- A. 1
 - B. 2
 - C. 3
 - D. 4
2. Liz writes the expression shown.

$$15 \times 4 \times 2$$

Which is **not** equivalent to the expression Liz writes?

- A. 30×4
 - B. $(15 \times 4) + (15 \times 2)$
 - C. 8×15
 - D. 120
3. Study the incomplete equation.

$$836 + 494 = 494 \underline{\hspace{2cm}}$$

Which operation symbol and number should be placed in the empty space to complete the equation?

- A. $\times 836$
- B. $\times 494$
- C. $+ 836$
- D. $+ 494$

4. Four students are asked to write an expression equivalent to $26 \times (4 + 6)$. Their answers are shown on the chart.

Student	Expression
Alex	$(26 \times 4) \times (26 \times 6)$
Belinda	$(26 + 4) \times (26 + 6)$
Cameron	$(26 + 4) + (26 + 6)$
Daisy	$(26 \times 4) + (26 \times 6)$

Which student's expression is correct?

- A. Alex
 - B. Belinda
 - C. Cameron
 - D. Daisy
5. Which expression has the same value as $13 + 8$?
- A. $(13 \times 4) + (13 \times 2)$
 - B. $8 + 8 + 5$
 - C. $15 - (2 + 8)$
 - D. $4 + 13 + 2$
6. Kayla plays a card game in which she matches equivalent expressions. Kayla selects the card shown.

$110 + 204$

Which card matches the card Kayla selects?

A.

$100 + 10 + 40 + 200$

B.

$10 \times (10 + 204)$

C.

$100 + 200 + 40$

D.

$200 + 110 + 4$

Name: _____

Standard NC.5.OA.3

Unit 1 - Study Guide

Use the information to answer questions 1–4.

Robin and Jamal staple papers to help their teacher.

- Robin staples papers in sets of 3.
- Jamal staples papers in sets of 6.

They each create a table to show the total number of stapled papers for different numbers of staples. Supply the missing numbers in the tables.

Robin's Staples

Staples Used	1	2	3	4	5
Total Papers					

Jamal's Staples

Staples Used	1	2	3	4	5
Total Papers					

1. What are the missing numbers in Robin's table?
 - A. 2, 4, 6, 8, 10
 - B. 6, 12, 18, 24, 30
 - C. 3, 6, 9, 12, 15
 - D. 4, 5, 6, 7, 8
2. What are the missing numbers in Jamal's table?
 - A. 6, 12, 18, 24, 30
 - B. 5, 10, 15, 20, 25
 - C. 6, 7, 8, 9, 10
 - D. 3, 6, 9, 12, 15

3. Robin and Jamal each create a set of ordered pairs in which the numbers of staples used represent x -values and the total papers represent y -values. Which statement is true?
 - A. Robin creates the ordered pairs (1, 3) and (3, 6).
 - B. Jamal creates the ordered pairs (3, 15) and (5, 30).
 - C. Both students create the ordered pairs (6, 12) and (12, 24).
 - D. Jamal creates the ordered pairs (1, 6) and (3, 18).
4. Graph the two sets of ordered pairs. Use orange for Robin's staples and blue for Jamal's staples.

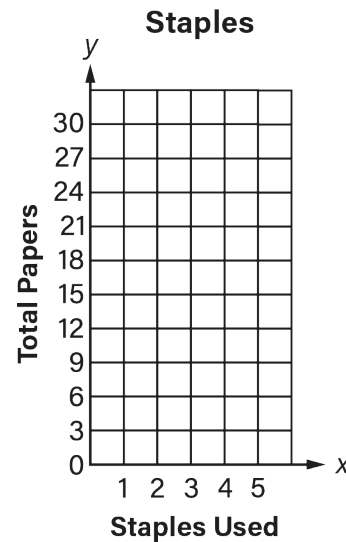

Which statement is true?

- A. Each of Robin's y -values is twice as much as Jamal's corresponding y -value.
- B. Each of Robin's y -values minus 3 equals Jamal's corresponding y -value.
- C. Each of Jamal's y -values is twice as much as Robin's corresponding y -value.
- D. Each of Jamal's y -values minus 3 equals Robin's corresponding y -value.

Name: _____

Standard NC.5.MD.5

Unit 1 - Study Guide

1. Lucy picks up her brother's blocks and stacks them in this box. The volume of the box is 490 cubic inches. How many inches tall is the box?

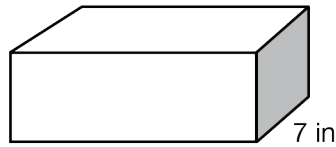

14 in
not drawn to scale

- A. 5 in
B. 6 in
C. 98 in
D. 392 in
2. Tim makes a tissue box. The area of the base is 45 square inches. The height of the box is 4 inches. What is the volume, in cubic inches, of the tissue box?
- A. 90 cubic inches
B. 180 cubic inches
C. 360 cubic inches
D. 1,080 cubic inches
3. A 28-foot trailer is shaped like a rectangular prism. The trailer is 8 feet wide and 9 feet high. What is the volume, in cubic feet, of the trailer?
- A. 45 cubic feet
B. 2,012 cubic feet
C. 2,016 cubic feet
D. 2,116 cubic feet

4. Mr. Ali is packing clothes in this box.

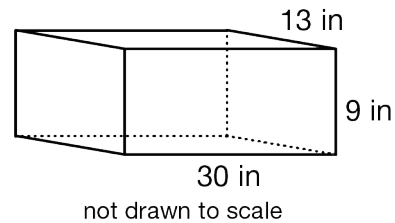

Which expression can Mr. Ali use to find the volume, in cubic inches, of the box?

- A. $(30 \times 13) \times (13 \times 9)$
B. $(30 \times 13) + (30 \times 9)$
C. $30 \times (9 \times 13)$
D. $30 \times (9 + 13)$
5. Ms. Robb builds concrete steps for a storage building, as shown. How many cubic inches of concrete does Ms. Robb use?

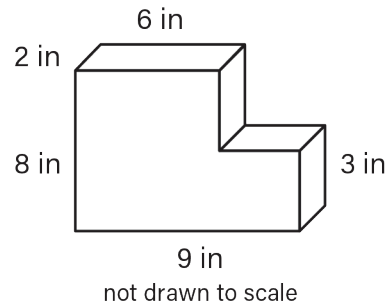

- A. 28 cubic inches
B. 114 cubic inches
C. 132 cubic inches
D. 144 cubic inches

Name: _____

Standard NC.5.MD.2

Unit 1 Study Guide

1. Carmen knits a scarf for her grandmother. She records the length of the scarf, in inches, after 1, 2, 3, and 4 hours of knitting.

Carmen's Scarf

Number of Hours	0	1	2	3	4
Total Length (in)	0	6	12	18	24

Carmen displays her data in a line graph. Which graph matches Carmen's data?

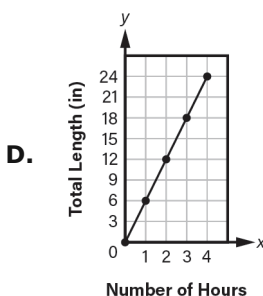
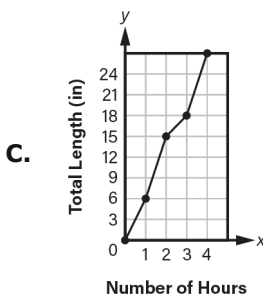
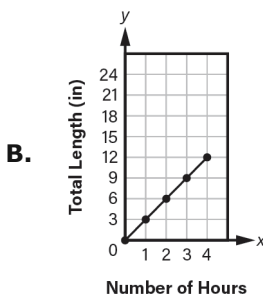
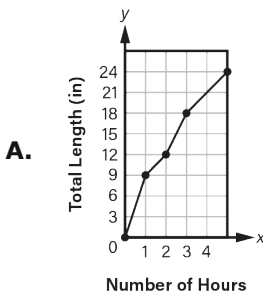

2. Carmen's brother, Miguel, is knitting a scarf for their grandfather. He uses a line graph to show the length of his scarf after 1, 2, 3, and 4 hours of knitting.

Miguel's Scarf

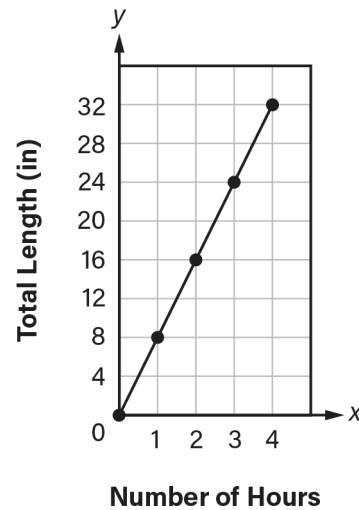

Based on Miguel's data, which statement is correct?

- A. The graph shows categorical data.
- B. Miguel knits more slowly than his sister, Carmen, in problem 1.
- C. The graph shows data that changes over time.
- D. Miguel and his sister Carmen knit the same number of inches each hour.
3. How many hours does it take Miguel to knit a 16-inch scarf?

- A. 1 hour
- B. 2 hours
- C. 3 hours
- D. 4 hours